

THREE YEAR LIMITED WARRANTY

R.L. DRAKE COMPANY warrants to the original purchaser this product shall be free from defects in material or workmanship for three (3) years from the date of original purchase.

During the warranty period the R.L. DRAKE COMPANY or an authorized Drake service facility will provide, free of charge, both parts and labor necessary to correct defects in material and workmanship. At its option, R.L. DRAKE COMPANY may replace a defective unit.

To obtain such warranty service, the original purchaser must:

- (1) Retain invoice or original proof of purchase to establish the start of the warranty period.
- (2) Notify the R.L. DRAKE COMPANY or the nearest authorized service facility, as soon as possible after discovery of a possible defect, of:
 - (a) the model and serial number,
 - (b) the identity of the seller and the approximate date of purchase; and
 - (c) A detailed description of the problem, including details on the electrical connection to associated equipment and the list of such equipment.
- (3) Deliver the product to the R.L. DRAKE COMPANY or the nearest authorized service facility, or ship the same in its original container or equivalent, fully insured and shipping charges prepaid.

Correct maintenance, repair, and use are necessary to obtain proper performance from this product. Therefore carefully read the Instruction Manual. This warranty does not apply to any defect that R.L. DRAKE COMPANY determines is due to:

- (1) Improper maintenance or repair, including the installation of parts or accessories that do not conform to the quality and specifications of the original parts.
- (2) Misuse, abuse, neglect or improper installation.
- (3) Accidental or intentional damage.

All implied warranties, if any, including warranties of merchantability and fitness for a particular purpose, terminate three (3) years from the date of the original purchase.

The foregoing constitutes R.L. DRAKE COMPANY'S entire obligation with respect to this product, and the original purchaser shall have no other remedy and no claim for incidental or consequential damages, losses or expenses. Some states do not allow limitations on how long an implied warranty lasts or do not allow the exclusions or limitation of incidental or consequential damages, so the above limitation and exclusion may not apply to you.

This warranty gives you specific legal rights and you may also have other rights which vary from state to state. This warranty shall be construed under the laws of Ohio.



R.L. DRAKE COMPANY
 230 INDUSTRIAL DRIVE
 FRANKLIN, OHIO 45005 U.S.A.
CUSTOMER SERVICE AND PARTS TELEPHONE:
 +1 (937) 746-6990
TELEFAX:
 +1 (937) 806-1576
WORLD WIDE WEB SITE: <http://www.rldrake.com>

DRAKE is a registered trademark of the R.L. Drake Company

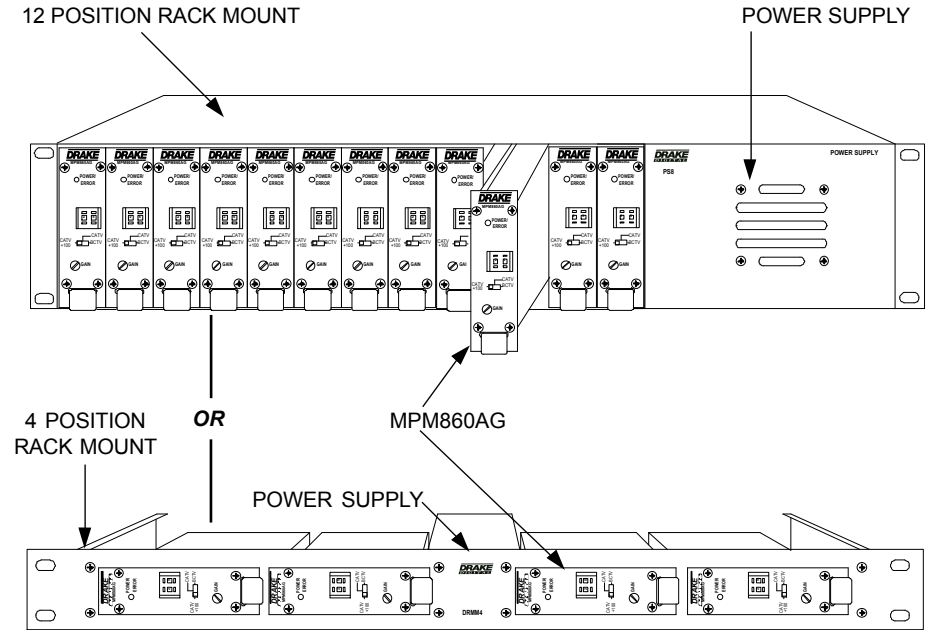

The MPM860AG mini processing module is a member of the R.L. Drake 19" Mini-Rack Series, a professional quality modular headend system designed to optimize rack space. An assortment of up to (12) modular units, such as the fixed channel series of modulators, or agile modulators, the MPM860AG, or compatible audio/video products can be racked alongside a single power supply in the Drake model RMM12, 12 position rack mount. The RMM4 rack mount accepts up to (4) modular units.

The R.L. Drake MPM860AG is a miniature analog double conversion heterodyne channel processor designed specifically to accept a channel 3 or channel 4 RF input from a typical consumer CH3/4 NTSC modulator. The input signal can be either double sideband as typical for such a modulator, or vestigial sideband modulated.

The MPM860AG contains SAW filtering to insure that the output of the MPM860AG is a vestigial sideband output for use in a 6 MHz wide channel environment. Adjacent output channels are allowed.

The frequency agile MPM860AG allows front panel pushwheel switch selection of standard CATV channels 2 through 135, or VHF/UHF TV channels 2 through 69. Aeronautical channels are offset per FCC requirements. Internal jumpers permit set up for HRC or IRC CATV plans as well.

The heterodyne conversion system, in conjunction with the use of a SAW filter, ensures optimum vestigial selectivity for adjacent channel headends.

Note that the output of the MPM860AG is related to the input signal's stability and level. A nominal input level of +10 dBmV ± 3 dB is desired at CH3 or CH4. The front panel gain control on the MPM860AG can then be adjusted to obtain a +45 dBmV output level. The MPM860AG is linear and if the input level is changed, the MPM output level will follow.

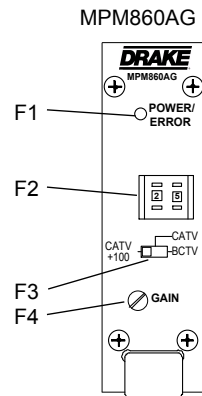

Figure 1

F1 - POWER/ERROR Indicator

Lights when the unit is connected to the required source of DC power via the rear panel DC INPUT connector. A flashing condition indicates an invalid channel setting or other conditions that would cause the unit to operate on an invalid channel. The RF output is switched off for flashing (ERROR) conditions.

F2 - Channel Select Switch

Sets the desired operating channel for standard CATV channels 02 through 135 or Broadcast TV channels 02 through 69. See also Item F3 which sets the type of channel (CATV or Broadcast TV) and sets the leading "1" for CATV channels 100 through 135.

F3 - Mode Switch

Sets the type of channel, CATV or Broadcast TV ("BC TV"). The first position of the switch

("+100") sets a leading "1" for CATV channels 100 through 135. See also Item F4 for setting the channel. Here are two examples:

Setting for CATV channel "125"-

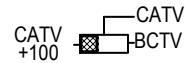
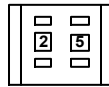

Setting for CATV channel "25"-

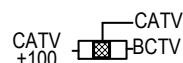
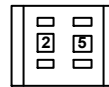
**F4 - Gain**

This screwdriver adjustment permits adjustment of the MPM860AG gain over a minimum of 10 dB range. Adjust to set output level to +45 dBmV.

The MPM860AG is linear and if the input level is changed, the MPM output level will follow.

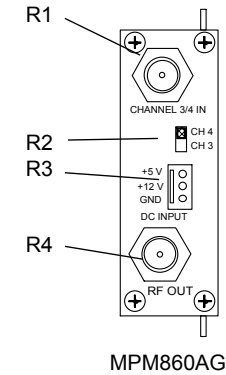

MPM860AG

Figure 2

R1 - CH 3 / CH 4 INPUT

+5 dBmV RF input.

R2 - Ch 3 / CH4 SELECT

Selects RF input between channel 3 and channel 4.

R3 - DC INPUT Connector

This 3-pin connector (Male) accepts the appropriate mating DC power cable.

R4 - RF OUTPUT

This is the +45 dBmV RF output.

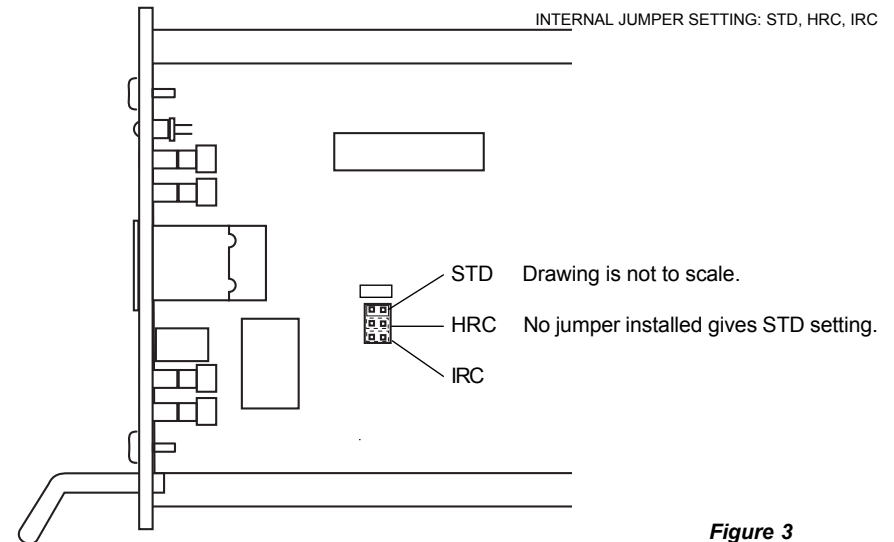

Figure 3

CONNECTIONS AND CONTROLS

All connections to and from each processor are made through the rear panel.

INSTALLATION NOTES

Level adjustment provides optimum performance in multi-channel installations. The output levels should be checked periodically with a spectrum analyzer or appropriate meter to insure output levels are properly set.

RACK MOUNTING

Adequate ventilation is very important in rack mounting installations. Excessive heat will shorten component life and performance.

The RMM12 or RMM4 cages should be spaced 1RU apart wherever possible. Some air movement is mandatory in enclosed rack cabinets.

POWER SUPPLY REQUIREMENT

Power for units mounted in the RMM12 rack mounting cage is to be supplied by a Drake model PSM121 power supply. Up to 12 processors may be powered.

The power supply in the four position rack system can power up to four MPM860AGs.

FREQUENCY CHART

The chart on the following page shows the standard CATV channel coverage. Where an offset is indicated, this amount of positive frequency offset is added to the frequency indicated in the middle column. As shown, this occurs only on channels required to be offset by the FCC.

HRC or IRC frequencies can be set by means of an internal jumper. See Figure 3. No jumper will result in the STD channel plan selection.

TABLE 1: CATV

Output Channel Switch Setting	Visual Carrier Frequency (MHz)	Frequency Offset (kHz)
02	55.25	NONE
03	61.25	NONE
04	67.25	NONE
05	77.25	NONE
06	83.25	NONE
07	175.25	NONE
08	181.25	NONE
09	187.25	NONE
10	193.25	NONE
11	199.25	NONE
12	205.25	NONE
13	211.25	NONE
14	121.25	+12.5
15	127.25	+12.5
16	133.25	+12.5
17	139.25	NONE
18	145.25	NONE
19	151.25	NONE
20	157.25	NONE
21	163.25	NONE
22	169.25	NONE
23	217.25	NONE
24	223.25	+12.5
25	229.25	+12.5
26	235.25	+12.5
27	241.25	+12.5
28	247.25	+12.5
29	253.25	+12.5
30	259.25	+12.5
31	265.25	+12.5
32	271.25	+12.5
33	277.25	+12.5
34	283.25	+12.5
35	289.25	+12.5
36	295.25	+12.5
37	301.25	+12.5
38	307.25	+12.5
39	313.25	+12.5
40	319.25	+12.5
41	325.25	+12.5
42	331.25	+25
43	337.25	+12.5
44	343.25	+12.5
45	349.25	+12.5
46	355.25	+12.5
47	361.25	+12.5
48	367.25	+12.5
49	373.25	+12.5
50	379.25	+12.5
51	385.25	+12.5
52	391.25	+12.5
53	397.25	+12.5
54	403.25	NONE
55	409.25	NONE
56	415.25	NONE
57	421.25	NONE
58	427.25	NONE
59	433.25	NONE
60	439.25	NONE
61	445.25	NONE
62	451.25	NONE
63	457.25	NONE
64	463.25	NONE
65	469.25	NONE
66	475.25	NONE
67	481.25	NONE
68	487.25	NONE
69	493.25	NONE

Output Channel Switch Setting	Visual Carrier Frequency (MHz)	Frequency Offset (kHz)
70	499.25	NONE
71	505.25	NONE
72	511.25	NONE
73	517.25	NONE
74	523.25	NONE
75	529.25	NONE
76	535.25	NONE
77	541.25	NONE
78	547.25	NONE
79	553.25	NONE
80	559.25	NONE
81	565.25	NONE
82	571.25	NONE
83	577.25	NONE
84	583.25	NONE
85	589.25	NONE
86	595.25	NONE
87	601.25	NONE
88	607.25	NONE
89	613.25	NONE
90	619.25	NONE
91	625.25	NONE
92	631.25	NONE
93	637.25	NONE
94	643.25	NONE
95	91.25	NONE
96	97.25	NONE
97	103.25	NONE
98	109.25	+25
99	115.25	+25
CATV +100		
100	649.25	NONE
101	655.25	NONE
102	661.25	NONE
103	667.25	NONE
104	673.25	NONE
105	679.25	NONE
106	685.25	NONE
107	691.25	NONE
108	697.25	NONE
109	703.25	NONE
110	709.25	NONE
111	715.25	NONE
112	721.25	NONE
113	727.25	NONE
114	733.25	NONE
115	739.25	NONE
116	745.25	NONE
117	751.25	NONE
118	757.25	NONE
119	763.25	NONE
120	769.25	NONE
121	775.25	NONE
122	781.25	NONE
123	787.25	NONE
124	793.25	NONE
125	799.25	NONE
126	805.25	NONE
127	811.25	NONE
128	817.25	NONE
129	823.25	NONE
130	829.25	NONE
131	835.25	NONE
132	841.25	NONE
133	847.25	NONE
134	853.25	NONE
135	859.25	NONE

TABLE 2: BC TV 

VHF BROADCAST CHANNELS	
Channel Number	Visual Carrier Frequency (MHz)
2	55.25
3	61.25
4	67.25
5	77.25
6	83.25
7	175.25
8	181.25
9	187.25
10	193.25
11	199.25
12	205.25
13	211.25

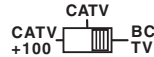

UHF BROADCAST CHANNELS	
Channel Number	Visual Carrier Frequency (MHz)
14	471.25
15	477.25
16	483.24
17	489.25
18	495.25
19	501.25
20	507.25
21	513.25
22	519.25
23	525.25
24	531.25
25	537.25
26	543.25
27	549.25
28	555.25
29	561.25
30	567.25
31	573.25
32	579.25
33	585.25
34	591.25
35	597.25
36	603.25
37	609.25
38	615.25
39	621.25
40	627.25
41	633.25
42	639.25
43	645.25
44	651.25
45	657.25
46	663.25
47	669.25
48	675.25
49	681.25
50	687.25
51	693.25
52	699.25
53	705.25
54	711.25
55	717.25
56	723.25
57	729.25
58	735.25
59	741.25
60	747.25
61	753.25
62	759.25
63	765.25
64	771.25
65	777.25
66	783.25
67	789.25
68	795.25
69	801.25

MPM860AG

Input

Input Level: -39 dBm / +10dBmV, ± 3 dB
 Input Impedance: 75 ohm, 18dB return loss
 Input frequency: Channel 3 (61.25 MHz Visual Carrier) or Channel 4 (67.25 MHz Visual carrier)
 Selectable via rear panel switch.

Output

Frequency Range: 54 to 864 MHz.
 Standard CATV channels 2 to 135, Normal operation.
 HRC, IRC Channels 1 - 135, Selected via internal jumper.
 Broadcast channels 2 - 69, Selected via internal jumper.

FCC Offsets: Automatic, +12.5 kHz or +25 kHz channel dependant.

Output level: +45 dBmV

Output Impedance: 75 Ohm, 10 dB return loss.

Frequency Stability: ± 5 kHz

Spurious: -60 dB @ +45 dBmV out.

Broadband Noise: -77dBc at greater than ± 12 MHz offset at +45 dBmV output, 4 MHz bandwidth.

In Channel C/N: 57 dB, 4 MHz bandwidth.

In Channel

Frequency Response: Within 2 dB

Output Level Note: The output level of the MPM860AG is intended to be set at or very near +45dBmV. The front panel gain control adjusts the input level into the conversion circuitry and not the final output attenuation. For best noise and spurious performance please adjust the output level to +45 dBmV with the actual input that will be used with the device. If more than 1 or 2 dB of variation is needed to properly equalize the system, appropriate pads should be placed at the output of the MPM860AG.

GENERAL

DC Power Input: +5 V $\pm 5\%$ at 400 mA
 +12 V $\pm 5\%$ at 200 mA

Operating Temperature: 0° C to +50° C ambient.

Size: 1" W x 3.5" H x 7.5" D

Weight: 12 oz.